

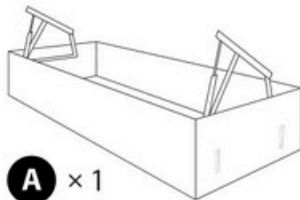

30 min

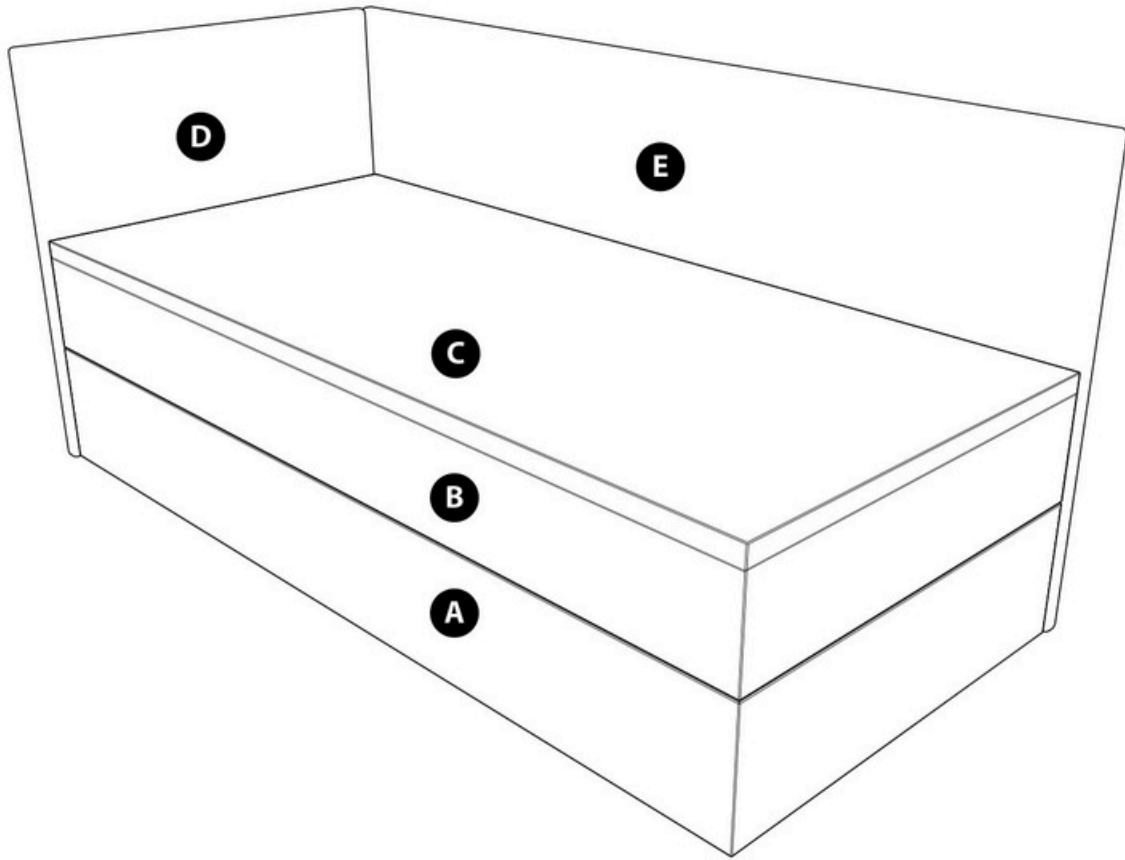

A × 1

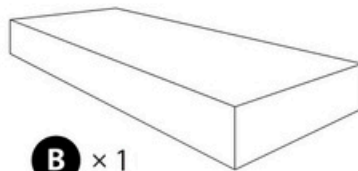

B × 1

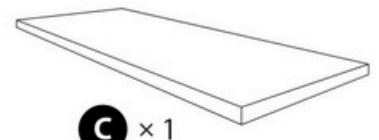

C × 1

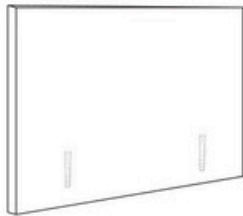

D × 1



E × 1

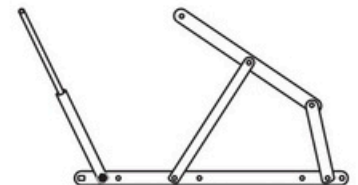

F × 2



M8 × 40 mm

G × 4



M8 × 20 mm

H × 6



M8 × 16 mm

I × 2



J × 2

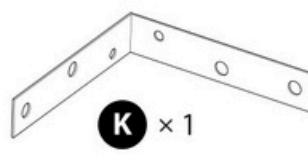

K × 1



M6 × 20 mm

L × 4



4,0 × 20 mm

M × 4

STEP 1

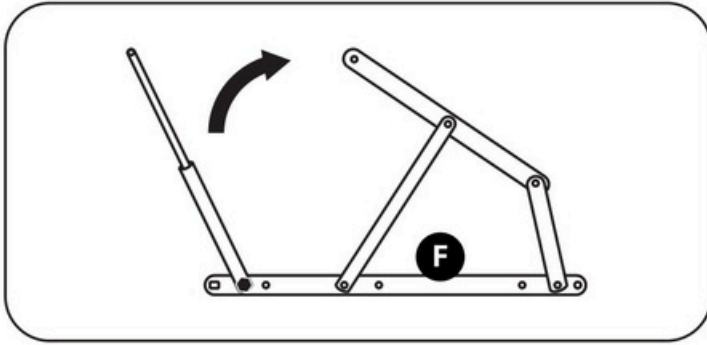

STEP 2

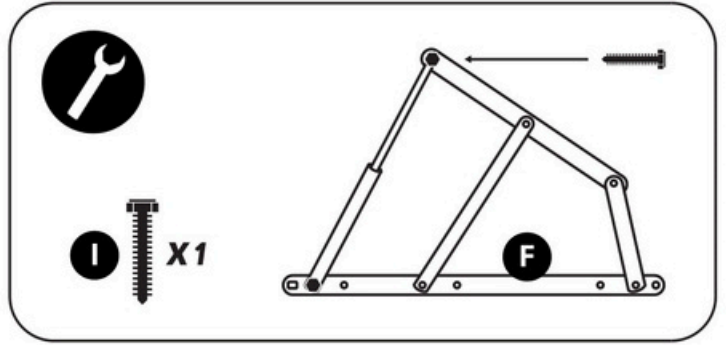

STEP 3

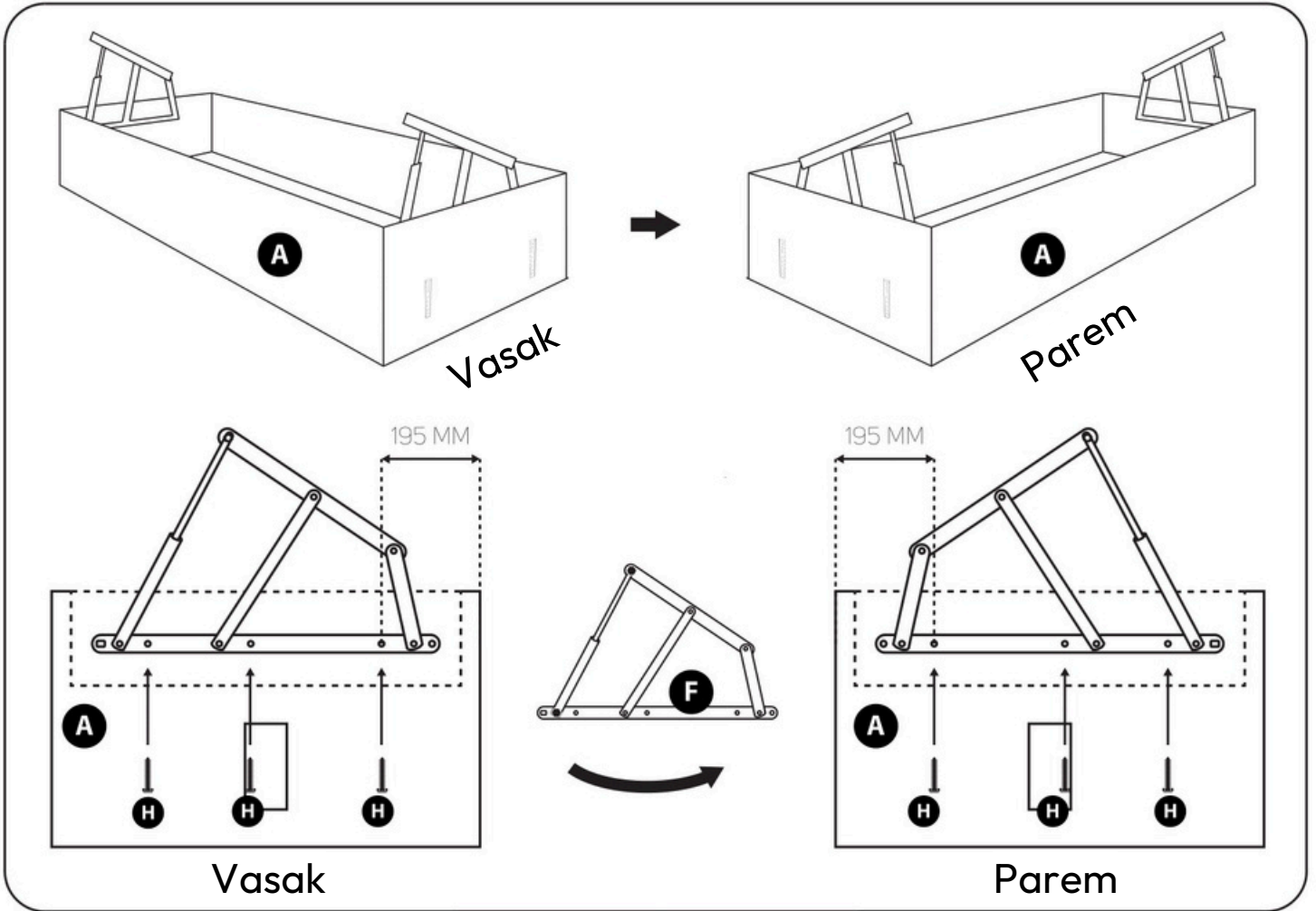

STEP 4

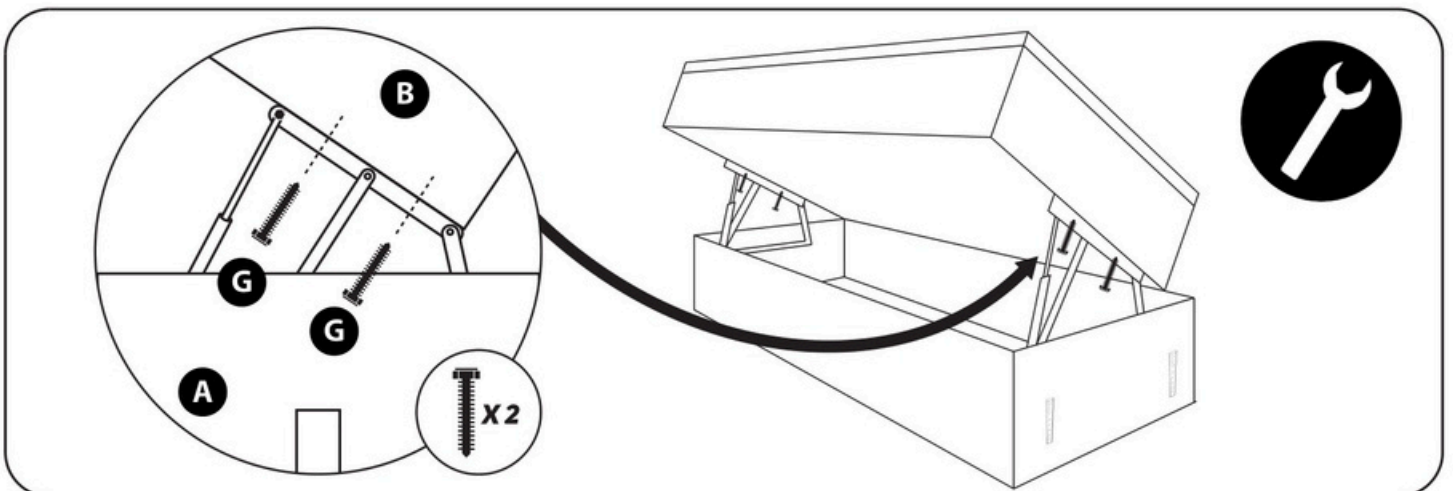

STEP 5

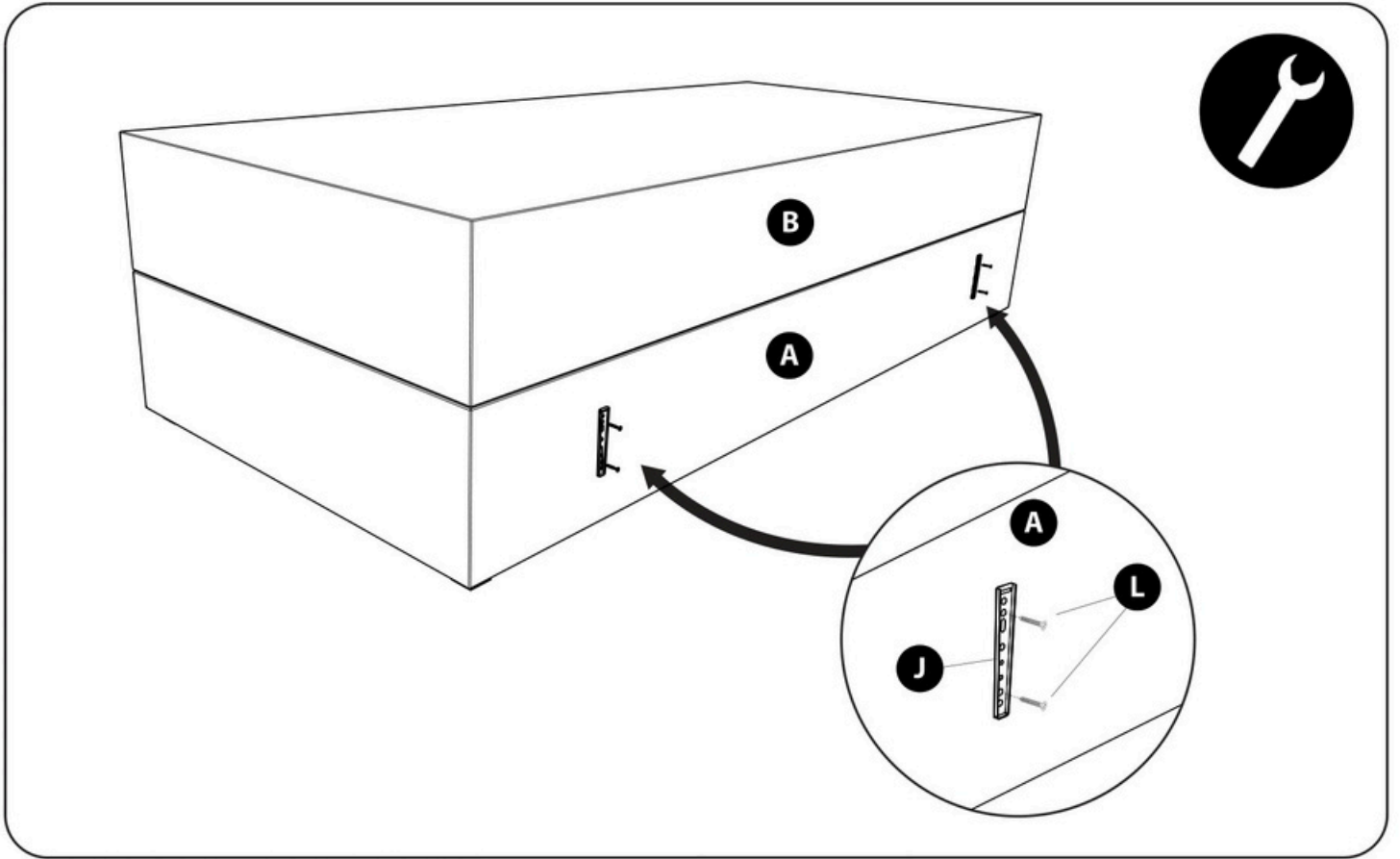

STEP 6

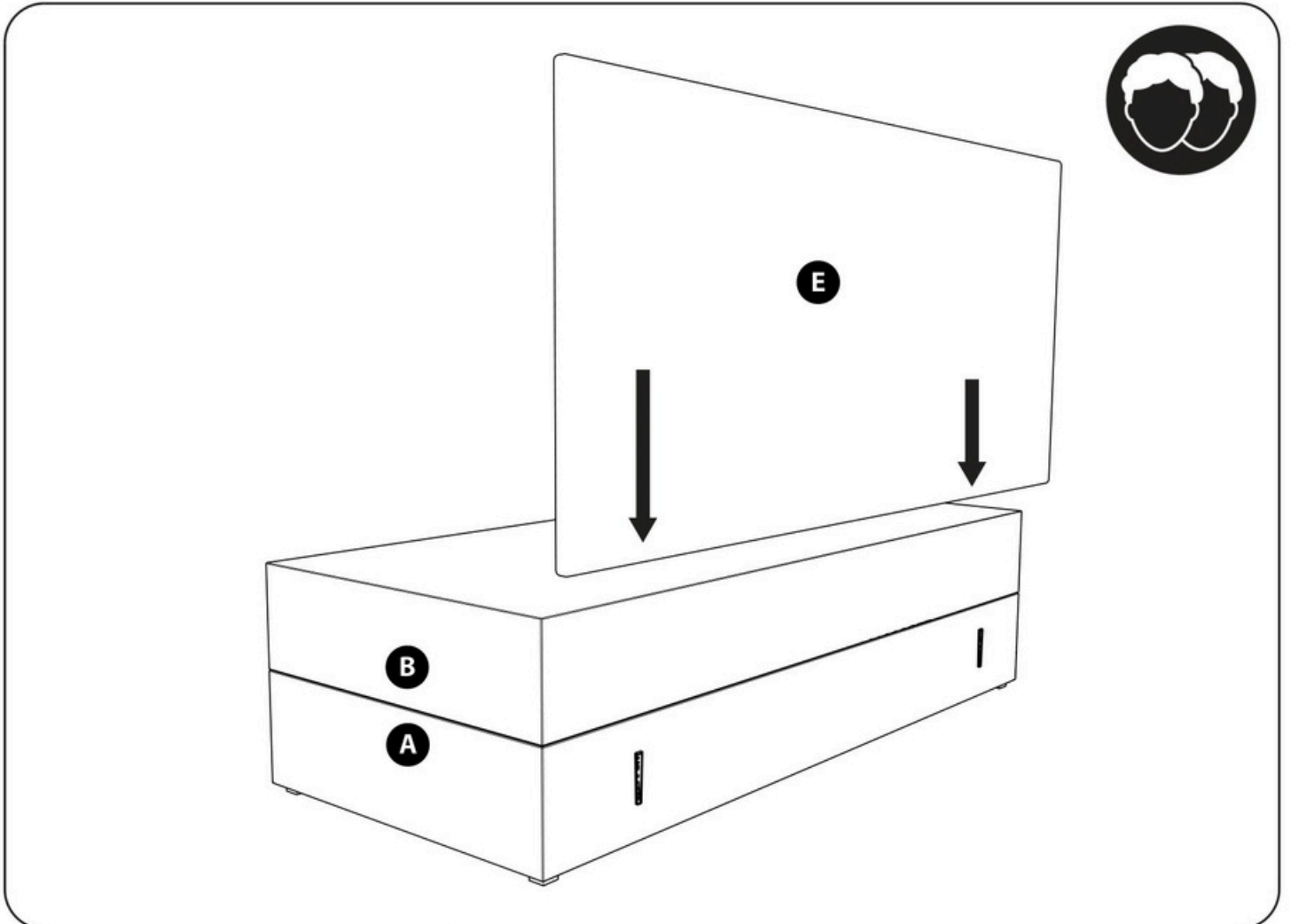

STEP 7

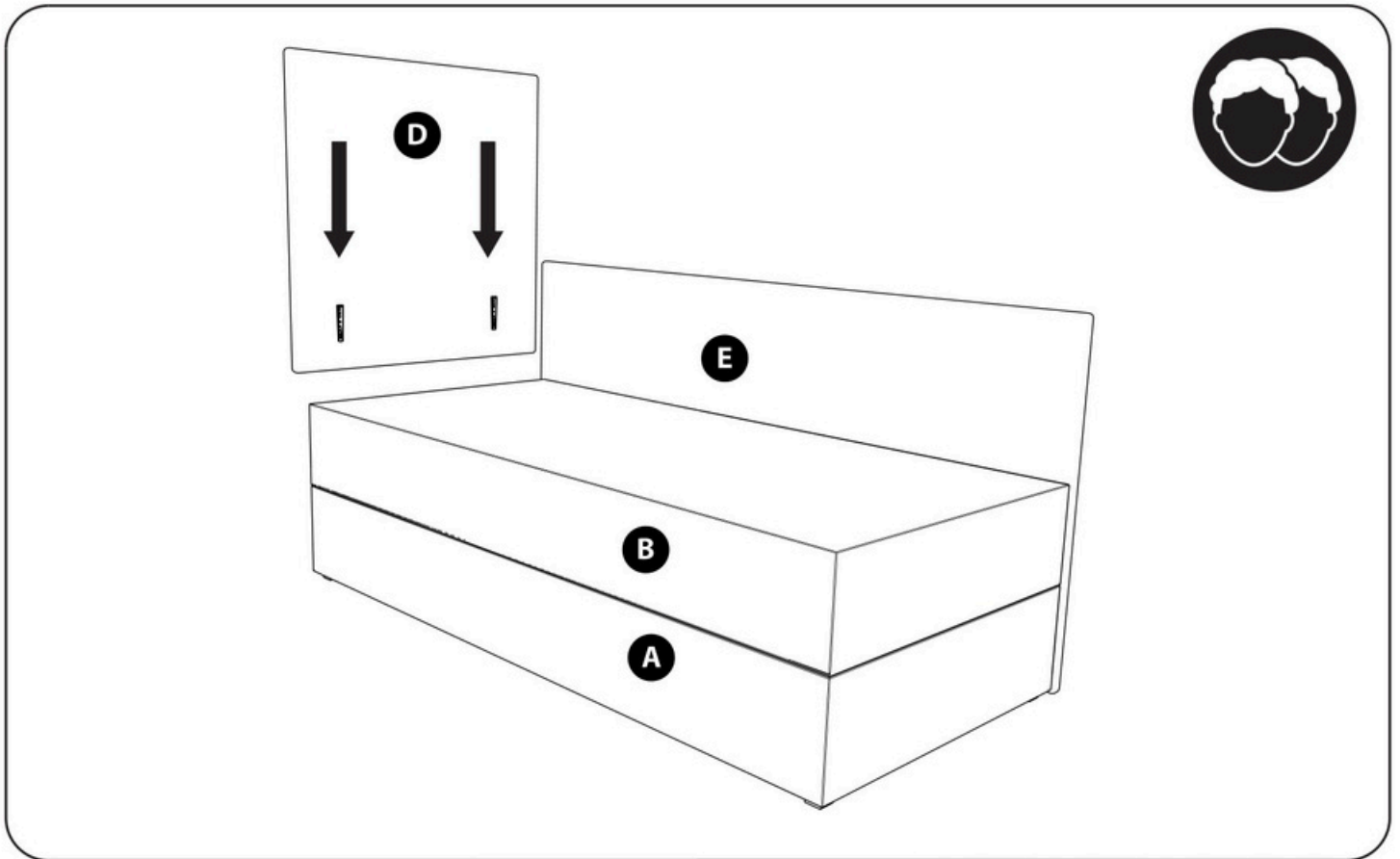

STEP 8

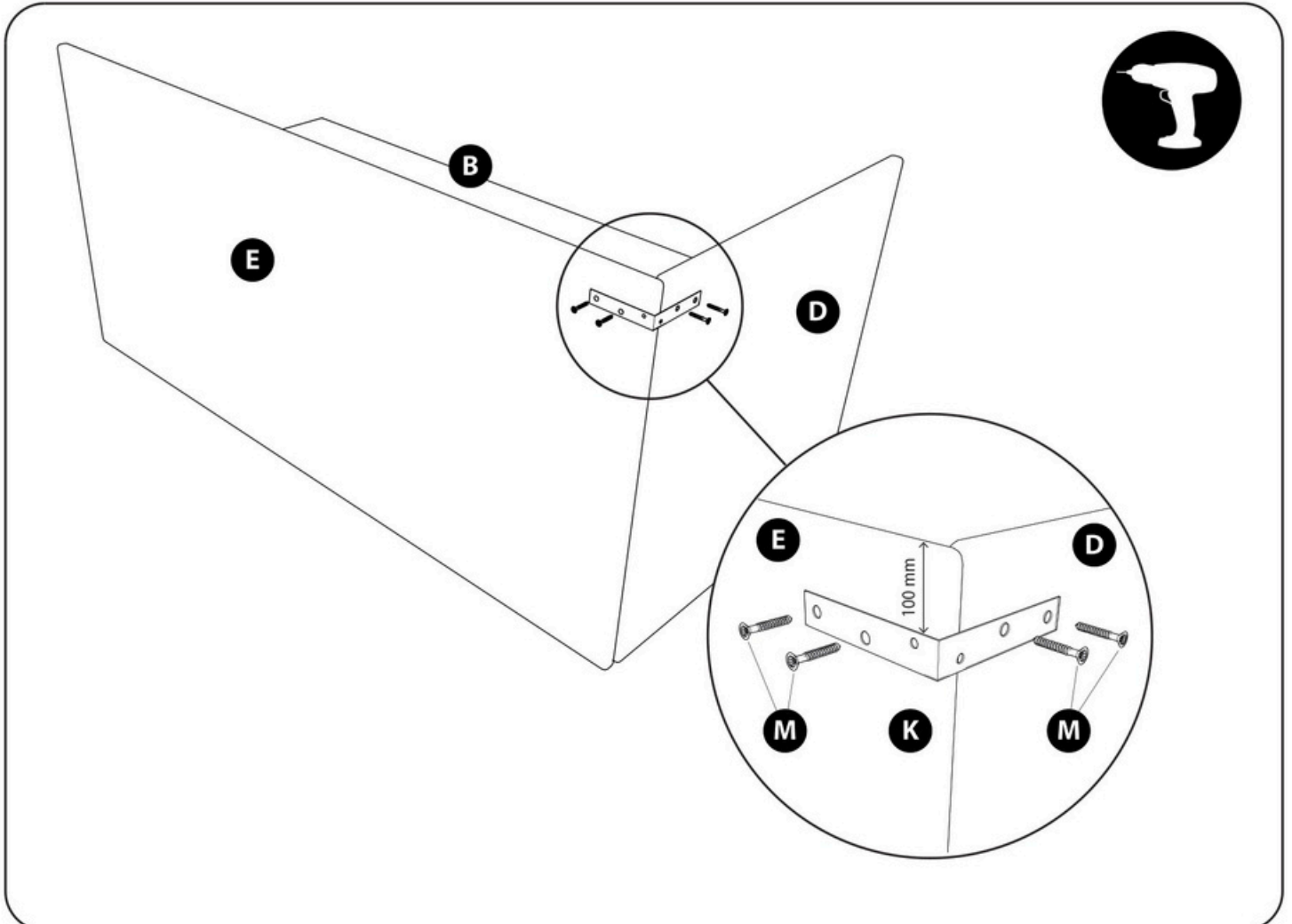

KONTINENTAALVOODI HOOLDUSJUHEND

Kvaliteetne kontinentaalvoodi pakub parimat magamismugavust aastaid, kui selle eest õigesti hoolt kanda. Mõned lihtsad harjumused aitavad säilitada voodi välimust, toetust ja vastupidavust pikaks ajaks.

Kasuta madratsikaitset. Madratsikaitse aitab vältida plekke, niiskust ja mustust ning pikendab nii madratsi kui ka voodi eluiga. Soovitame valida pestava, hingava ja veekindla kaitsekatte.

Ära istu pidevalt voodi serval. Voodi serv on kõige tundlikum piirkond ning pidev istumine samas kohas võib põhjustada selle vajumist. Istumiseks on parem kasutada madratsi keskmist osa või eraldi tumbat.

Väldi liigset raskust ja hüppamist voodil. Kontinentaalvoodi konstruktsioon on mõeldud magamiseks, mitte hüppamiseks või raskete esemete hoidmiseks. Liigne koormus võib kahjustada vedrustust ja raamistikku.

Puhasta voodi regulaarselt. Eemalda tolmu õrnalt tolmuimejaga, kasutades pehmet otsikut. Polsterdust ja kangast puhasta vastavalt materjali hooldusjuhiste.

Kontrolli jalgu ja ühenduskohti. Kord kvartalis tasub üle vaadata, et voodijalad ja kõik ühendusdetailid oleksid kindlalt pingul ja stabiilsed.